

1550nm High Power Polarization Insensitive Semiconductor Optical Amplifier

1550nm High Power Polarization Insensitive Semiconductor Optical Amplifier (SOA) is a optic active product which can boost the intensity of optical signal in a fiber optic communication system. The SOA built with angled multi-quantum-well chip to output stable amplified light, all of the polarization light will be amplified, the TEC and Thermistor built in to control the device temperature. It features high optical gain, high saturation output power, it's widely used in Optical Line Amplifier, Optic Non-linear Application and Optoelectronic Integration field, the output signal power can be customized.

Application:

Optical Line Amplifier
Optic Non-linear Application
Optoelectronic Integration
WDM System

Features:

High Optical Gain
Low Polarization Sensitivity
Isolator, TEC and Thermistor Built In
High Reliability



Absolute Maximum Ratings:

Parameter	Symbol	Value	Unit
SOA Forward Current	I _f	1200	mA
SOA Forward Voltage	V _f	2	V
Operating Temperature	T	-40~+60	°C
Storage Temperature	T	-40~+85	°C
Solder Temperature	T	260	°C
Lead Solder Time		10	S

Notice: Above specifications should not be exceeded, or the device will be seriously damaged.

Optical and Electrical Specification:

Parameter	Symbol	Min.	Tpy.	Max.	Unit	Test Condition
Center Wavelength	λ _c		1550		nm	
3dB Wavelength Bandwidth	BW	70			nm	
3dB Saturated Output Power		22	23	25	dBm	CW, I _f =900mA
Small Signal Gain	G			35	dB	CW, P _i =-20dBm
Gain Ripple	ΔG		1.0	1.5	dB	λ _c
Noise Figure			7.5		dB	
Polarization dependent Gain	PDG		4		dB	
Optical Isolation	ISO	30			dB	
SOA Operating Current	I _{op}		900	1200	mA	CW
TEC Current	I _{tec}			2	A	-10~70°C
TEC Voltage	V _{tec}			3.6	V	
TEC Set Temperature	T	15		35	°C	
Thermistor Current	I _{the}			5	mA	
Air Tightness		10 ⁻¹²	10 ⁻¹¹	10 ⁻⁸	Pa.m ³ /s	T=25°C
Thermistor Resistance	R _{the}	9.5	10	10.5	KΩ	T=25°C
Thermistor Temperature	T			100	°C	
Fiber Type		SMF-28e Fiber				

Notice: Above specifications are tested at in room temperature at 23°C.

Specifications may change without notice.

Drawing:

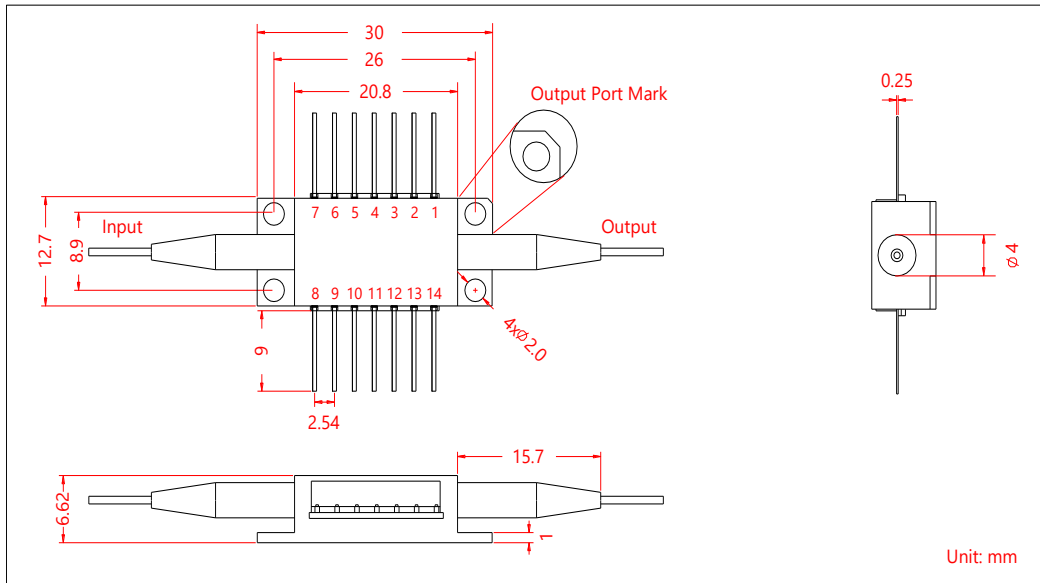

Pin Information:

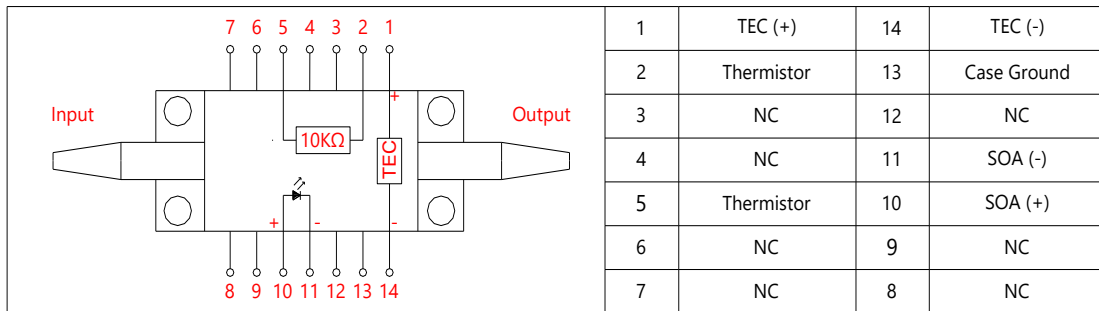

Ordering Information (Part Number):

PISOA-WWW-OO-J-LL-CC

WWW	OO	J	LL	CC
Wavelength	Output Power	Fiber Jacket	Fiber Length	Connector
1550 - 1550nm	23 - 23dBm SS - Specify	B - 250um Bare Fiber L - 900um Loose Tube	05 - 0.5m 10 - 1.0m 15 - 1.5m 20 - 2.0m SS - Specify	NE - None FA - FC/APC FU - FC/UPC LA - LC/APC LU - LC/UPC SA - SC/APC SU - SC/UPC SS - Specify

Notification:

1. The Semiconductor Optoelectronic products are particularly sensitive of ESD (electro-static discharge), it's recommended to use grounded anti-static wrist straps and grounded anti-static mats before handling the products.
2. Never plug or unplug the products under a living circuit, setting the current supply to zero before switching on or switching off the products.
3. Always take anti-static measures to storage the products when not in use.

