

## 1650nm SM Pigtailed DFB Laser Diode

1650nm SM Pigtailed DFB ( Distributed Feedback) Laser Diode is a semiconductor optoelectronic product which can output stable laser light by the pigtailed singlemode fiber, it's widely used in Telecom Data Transfer, Fiber Optic Sensor Application, the DFB Laser Diode also with PD built in to monitor the signal power, the pigtail also can be customized to MM, PM type upon request.

### Application:

Data Transmission  
Fiber Optic Sensor  
Laser Imaging  
Testing System

### Features:

Low Threshold Current  
High Output Power  
PD and Isolator Built In  
High Reliability



### Absolute Maximum Ratings:

Parameter	Symbol	Value	Unit
LD Forward Current	If	150	mA
LD Reverse Voltage	Vr	2	V
PD Forward Current	If(PD)	2	mA
PD Reverse Voltage	Vr(PD)	15	V
Operating Temperature	T	-40~+85	°C
Storage Temperature	T	-40~+85	°C
Solder Temperature	T	260	°C
Lead Solder Time		10	S

Notice: Above specifications should not be exceeded, or the LD will be seriously damaged.

### Optical and Electrical Specification:

Parameter	Symbol	Min.	Tpy.	Max.	Unit	Test Condition
Center Wavelength	$\lambda_c$	1640	1650	1660	nm	
Optical Power	Po	1	3		mW	CW
Spectral Width @-20dB	$\Delta\lambda$		0.1	1	nm	CW
Optical Isolation	For Single Stage	ISO	30	35	dB	
	For Dual Stage	ISO	50	55	dB	
Threshold Current	I <sub>th</sub>		12		mA	CW
LD Operating Current	I <sub>op</sub>		30	40	mA	CW, Po=2mW
LD Forward Voltage	V <sub>f</sub>		1.1	1.6	V	CW
Response Time (Raise/Fall)	T <sub>r</sub> /T <sub>f</sub>		0.2		ns	
Monitor Dark Current	I <sub>d</sub>			200	nA	V <sub>r</sub> (PD)=5V
PD Monitor Current	I <sub>m</sub>	0.02	1		mA	CW
Modulation Bandwidth	BW	1.25	2.5	4.25	GHz	
Side Mode Suppression Ratio	SMSR	35	40		dB	
Fiber Type	SMF-28e Fiber					

Notice: Above specifications are tested in room temperature at 23°C.  
Specifications may change without notice.

**Drawing:**

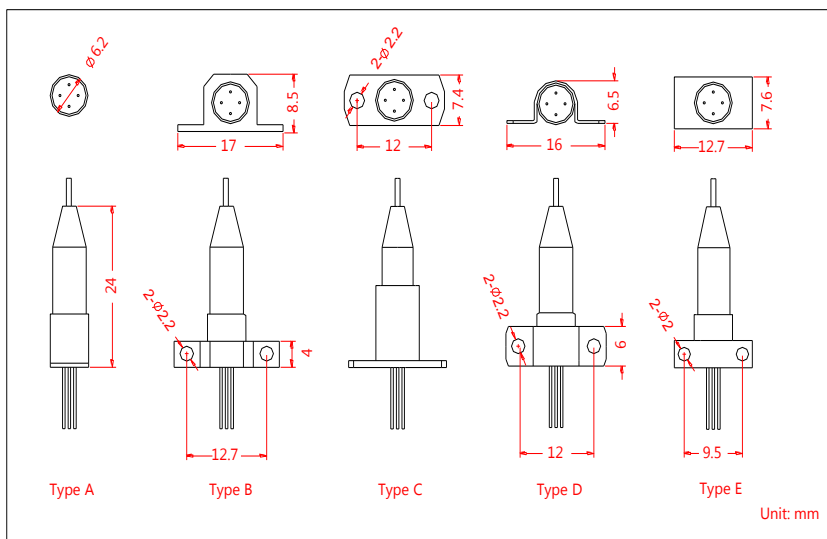

**Pin Information:**

	Type A		Type B		Type C	
	Pin 1	PD (+)	Pin 1	PD (-)	Pin 1	PD (-)
	Pin 2	LD (+), PD (-)	Pin 2	PD (+)	Pin 2	LD (-)
	Pin 3	Case	Pin 3	LD (+), Case	Pin 3	LD (+), Case
	Pin 4	LD (-)	Pin 4	LD (-)	Pin 4	PD (+)

**Ordering Information (Part Number):**

**SMDPLD-WWW-OO-I-S-P-FF-J-LL-CC**

<b>WWW</b>	<b>OO</b>	<b>I</b>	<b>S</b>	<b>P</b>	<b>FF</b>	<b>J</b>	<b>LL</b>	<b>CC</b>
Wavelength	Optical Power	Isolator	Saddle Type	Pin Assingment	Fiber Type	Fiber Jacket	Fiber Length	Connector
1650 - 1650nm	01 - 1mW 02 - 2mW 03 - 3mW SS - Specify	N - None S - Single D - Dual	A - Type A B - Type B C - Type C D - Type D E - Type E	A - Type A B - Type B C - Type C	S2 - SMF-28e	B - 250um Bare Fiber L - 900um Loose Tube	05 - 0.5m 10 - 1.0m 15 - 1.5m 20 - 2.0m SS - Specify	NE - None FA - FC/APC FU - FC/UPC LA - LC/APC LU - LC/UPC SA - SC/APC SU - SC/UPC SS - Specify

**Notification:**

1. The Semiconductor Optoelectronic products are particularly sensitive of ESD (electro-static discharge), it's recommended to use grounded anti-static wrist straps and grounded anti-static mats before handling the products.
2. Never plug or unplug the products under a living circuit, setting the current supply to zero before switching on or switching off the laser diode.
3. Always take anti-static measures to storage the products when not in use.

