

1310nm PM Semiconductor Optical Amplifier

1310nm PM Semiconductor Optical Amplifier (SOA) is a optic active product which can boost the intensity of optical signal in a fiber optic communication system. The SOA built with angled multi-quantum-well chip to output stable amplified light, one single polarization light will be amplified, the TEC and Thermistor built in to control the device temperature. It features high optical gain, high saturation output power, it's widely used in Optical Line Amplifier, Optic Non-linear Application and Optoelectronic Integration field, the output signal power can be customized.

Application:

Optical Line Amplifier
 Optic Non-linear Application
 Optoelectronic Integration
 WDM System

Features:

High Optical Gain
 High Polarization Extinction Ratio
 Isolator, TEC and Thermistor Built In
 High Reliability



Absolute Maximum Ratings:

Parameter	Symbol	Value	Unit
SOA Forward Current	I _f	400	mA
SOA Forward Voltage	V _f	1.8	V
Operating Temperature	T	-10~+70	°C
Storage Temperature	T	-40~+85	°C
Solder Temperature	T	260	°C
Lead Solder Time		10	S

Notice: Above specifications should not be exceeded, or the device will be seriously damaged.

Optical and Electrical Specification:

Parameter	Symbol	Min.	Tpy.	Max.	Unit	Test Condition
Center Wavelength	λ_c	1290	1310	1330	nm	
3dB Wavelength Bandwidth	BW	40			nm	
3dB Saturated Output Power		10	12		dBm	CW, I _f =250mA
Small Signal Gain	G	15	20	25	dB	CW
Gain Ripple	ΔG		1.0	1.5	dB	λ_c
Noise Figure			7.5	9	dB	
Polarization Extinction Ratio	ER	22			dB	
Polarization Dependent Gain	PDG			2	dB	
SOA Operating Current	I _f		250	400	mA	CW
TEC Current	I _{tec}			1.5	A	-10~70°C
TEC Voltage	V _{tec}			3.5	V	
TEC Set Temperature	T	15		35	°C	
Thermistor Current	I _{the}			5	mA	
Thermistor Resistance	R _{the}	9.5	10	10.5	K Ω	T=25°C
Thermistor Temperature	T			100	°C	
Fiber Type		PM 1310 Panda Fiber				

Notice: Above specifications are tested at in room temperature at 23°C.

Slow axis is default aligned to the connector key.

Specifications may change without notice.

Drawing:

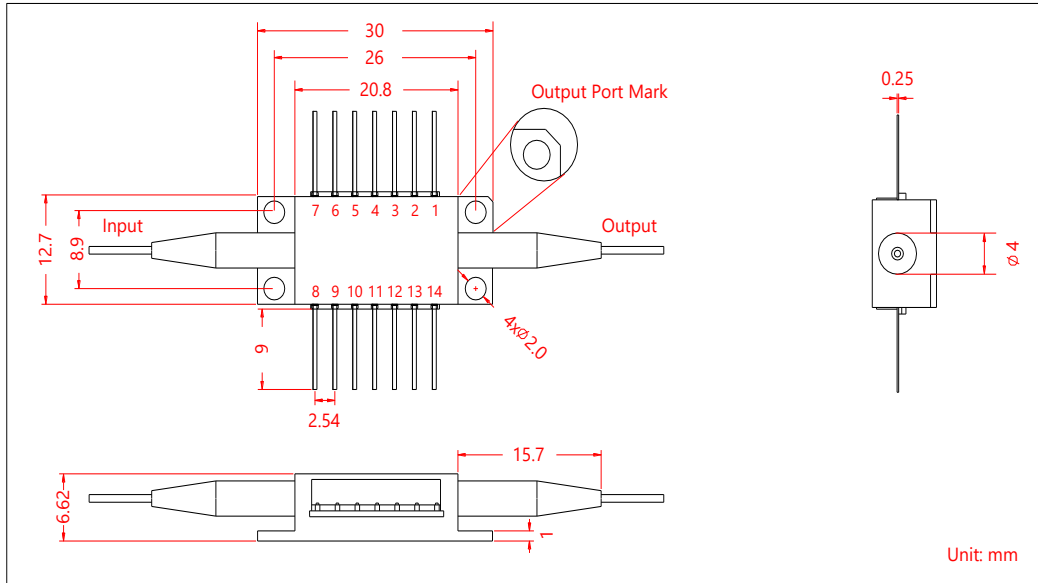

Pin Information:

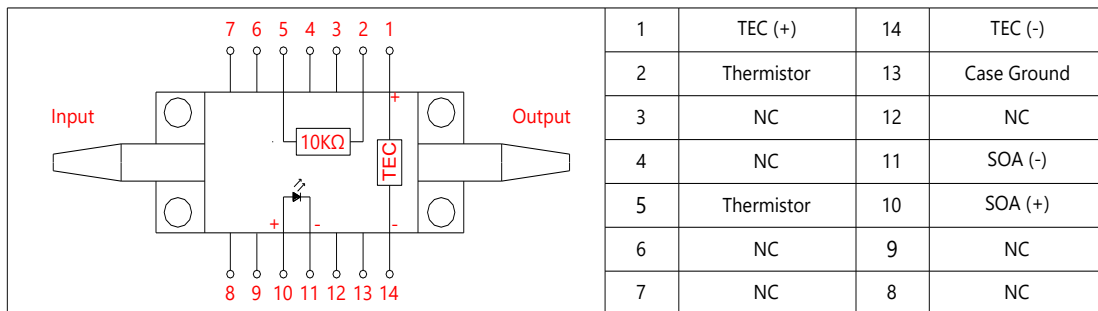

Ordering Information (Part Number):

PMSOA-WWWW-OO-J-LL-CC

WWWW	OO	J	LL	CC
Wavelength	Output Power	Fiber Jacket	Fiber Length	Connector
1310 - 1310nm	05 - 5dBm 08 - 8dBm 10 - 10dBm 13 - 13dBm SS - Specify	B - 250um Bare Fiber L - 900um Loose Tube	02 - 0.2m 05 - 0.5m 10 - 1.0m 15 - 1.5m 20 - 2.0m SS - Specify	NE - None FA - FC/APC FU - FC/UPC LA - LC/APC LU - LC/UPC SA - SC/APC SU - SC/UPC SS - Specify

Notification:

1. The Semiconductor Optoelectronic products are particularly sensitive of ESD (electro-static discharge), it's recommended to use grounded anti-static wrist straps and grounded anti-static mats before handling the products.
2. Never plug or unplug the products under a living circuit, setting the current supply to zero before switching on or switching off the products.
3. Always take anti-static measures to storage the products when not in use.

