

## 1550nm Pluggable InGaAs PIN Photodiode

1550nm Pluggable InGaAs PIN Photodiode is an optoelectronic product which can detect light signal by transferring the light optical signal to electric signal, it's built with InGaAs chip material to detect the light signal from the input port. The InGaAs Photodiode (PD) is widely used for monitoring the optical power or detecting the signal in fiber optic sensor and optic electric communication field. The pluggable type can be SC, FC, ST.

### Application:

Analog Optical Transmission  
Fiber Optic Sensor  
Computed Tomography  
Testing System

### Features:

High Response  
Low Dark Current  
Low Capacitance  
High Reliability



### Absolute Maximum Ratings:

Parameter	Symbol	Value	Unit
Reverse Voltage	Vr	30	V
Forward Current	If	10	mA
Operating Temperature	T	-40~+85	°C
Storage Temperature	T	-40~+85	°C
Solder Temperature	T	260	°C
Lead Solder Time		10	S

Notice: Above specifications should not be exceeded, or the Photodiode will be seriously damaged.

### Optical and Electrical Specification:

Parameter	Symbol	Min.	Tpy.	Max.	Unit	Test Condition
Center Wavelength	$\lambda_c$	1100	1550	1650	nm	
Saturation Input Power	P			10	mW	CW
Dark Current	Id		0.05	1	nA	
Responsivity	R		0.85		A/W	Vr=5V
Frequency Bandwidth	Bw		2.5		GHz	
Junction Capacitance	Cj			0.75	pF	Vr=5V
Active Diameter	Ad	55	75	1000	um	
Response Time (Raise/Fall)	Tr/Tf			1	ns	
Return Loss	RL	45			dB	
Pluggable Type		FC, SC, ST				

Notice: Above specifications are tested in room temperature at 25°C.

Specifications may change without notice.

**Drawing:**

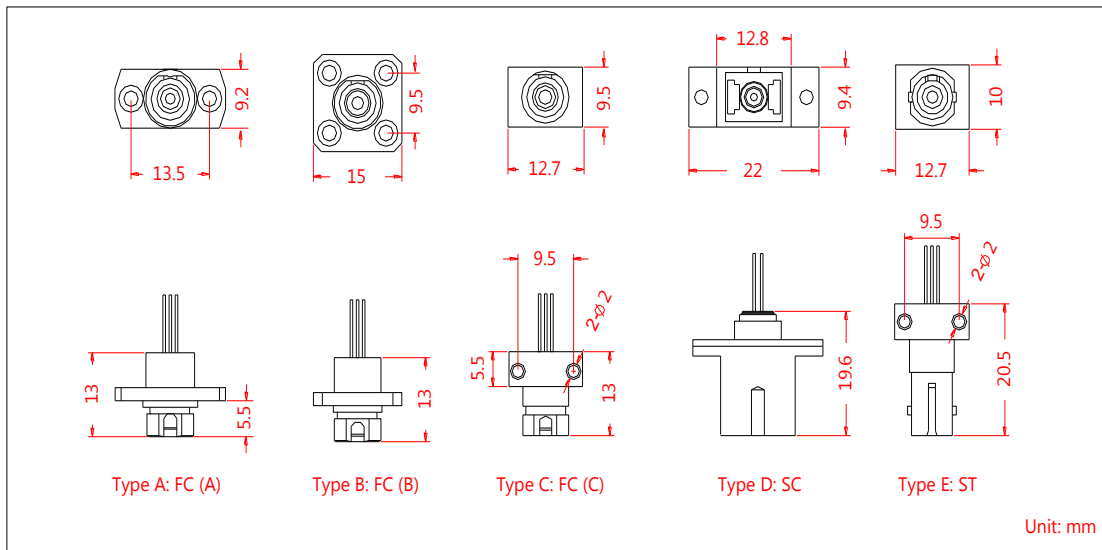

**Pin Information:**

	Type A			Type B			Type C	
	Pin 1	PD +		Pin 1	PD +		Pin 1	PD +
	Pin 2	PD -		Pin 2	PD -		Pin 2	Case
	Pin 3	Case		Pin 3	Case		Pin 3	PD -

**Ordering Information (Part Number):**

**PIPD-WWW-AA-T-P**

<b>WWW</b>	<b>AA</b>	<b>T</b>	<b>P</b>
Wavelength	Active Diameter	Package Type	Pin Assigment
1550 - 1550nm	55 - 55um 60 - 60um 75 - 75um 80 - 80um 1H - 100um 1K - 1000um	A - Type A B - Type B C - Type C D - Type D E - Type E	A - Type A B - Type B C - Type C

**Notification:**

1. The Semiconductor Optoelectronic products are particularly sensitive of ESD (electro-static discharge), it's recommended to use grounded anti-static wrist straps and grounded anti-static mats before handling the products.
2. Always take anti-static measures to storage the products when not in use.

