

980nm 1x3 3x3 PM Fiber Fused Coupler

980nm 1x3 3x3 Polarization Maintaining (PM) Fused Coupler is built with fused biconical taper (FBT) technology, it can be used in split the optical signal power into three parts with even or various coupling ratio and keep the polarization maintaining, it's widely applied in fiber optic sensor, fiber amplifier system and fiber optic diffraction field.

Application:

Fiber Optic Amplifier
Fiber Optic Sensor
Fiber Laser
Optical Diffraction System

Features:

Low Excess Loss
Low Insertion Loss
High Extinction Ratio
High Reliability



Specification:

Parameter	Symbol	Value	Unit	
Center Wavelength	λ	980	nm	
Bandwidth	BW	± 20	nm	
Max. Excess Loss	EL	1.0	dB	
Max. Coupling Ratio Tolerance	CR	5/90/5	$5 \pm 1.5 / 90 \pm 2.5 / 5 \pm 1.5$	%
		10/80/10	$10 \pm 1.6 / 80 \pm 2.8 / 10 \pm 1.6$	%
		15/70/15	$15 \pm 1.8 / 70 \pm 3.0 / 15 \pm 1.8$	%
		20/60/20	$20 \pm 2.0 / 60 \pm 3.3 / 20 \pm 2.0$	%
		25/50/25	$25 \pm 2.4 / 50 \pm 3.5 / 25 \pm 2.4$	%
		30/40/30	$30 \pm 3.0 / 40 \pm 4.0 / 30 \pm 3.0$	%
		33/33/33	$33 \pm 6.0 / 33 \pm 6.0 / 33 \pm 6.0$	%
Min. Extinction Ratio	ER	For Ratio > 10% Port	16	dB
		For $5\% \leq \text{Ratio} \leq 10\%$ Port	14	dB
		For Ratio < 5% Port	12	dB
Fiber Type		PM Panda Fiber	-	
Max. Tensile Load		5	N	
Max. Optical Power (CW)	P	2	W	
Operating Temperature	T	-40~75	°C	
Storage Temperature	T	-40~85	°C	
Package Dimension		$\Phi 3.0 \times L54$ for 250um bare fiber $\Phi 4.0 \times L70$ for 900um loose tube	mm	

Notice: Above specifications are tested at center wavelength without connector in room temperature @23°C.

For devices with connectors, IL will be 0.3dB higher, EL will be 0.2dB higher, ER will be 2dB lower, slow axis is default aligned to the connector key.

If need optical power more than 2W CW, please contact us to confirm. Connectors only 1W (Continue Wavelength) optical power guarantee.

Drawing:

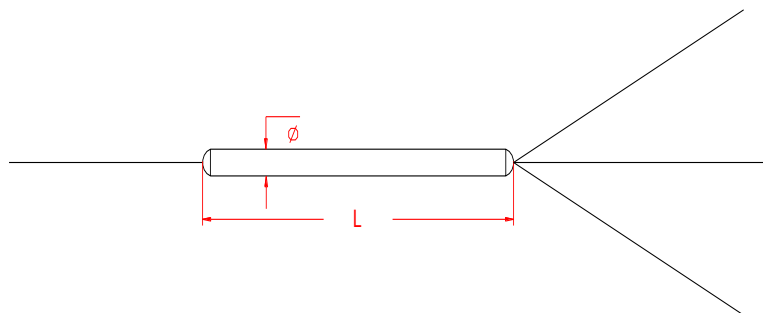

Ordering Information (Part Number):**PMFUC-WWW-PP-A-RR-J-LL-CC**

WWW	PP	A	RR	J	LL	CC
Wavelength	Port	Working Axis	Coupling Ratio	Fiber Jacket	Fiber Length	Connector
975 - 975nm	13 - 1x3	B - Both Axes	05 - 5/90/5	B - 250um	05 - 0.5m	NE - None
980 - 980nm	33 - 3x3	Working	10 - 10/80/10	Bare Fiber	10 - 1.0m	FA - FC/APC
		S - Slow Axis	15 - 15/70/15	9 - 900um	15 - 1.5m	FU - FC/UPC
		Working	20 - 20/60/20	Loose Tube	20 - 2.0m	SA - SC/APC
		F - Fast Axis	25 - 25/50/25		SS - Specify	SU - SU/APC
		Working	30 - 30/40/30			LA - LC/APC
			33 - 33/33/33			LU - LC/UPC
			40 - 40/20/40			SS - Specify
			SS - Specify			