

640nm PM 3-port Optical Circulator

640nm PM 3-port Optical Circulator is a fiber passive component built with TGG crystal, which can change signal light transmission path, the signal can be delivered from Port 1 to Port 2, the other signal light from Port 2 to Port 3, the high isolation can block the back reflection light. It's widely used in Quantum Communication, Fiber Laser and Coherent Detecting field. If need higher power version please tell us to confirm.

Application:

Quantum Communication
Fiber Laser
Coherent Detecting
Lab&Research

Features:

High Extinction Ratio
High Isolation
Low Insertion Loss
High Reliability



Specification:

Parameter	Symbol	Value	Unit
Center Wavelength	λ	640	nm
Bandwidth	BW	± 5	nm
Typ. Insertion Loss (Port 1 to 2, 2 to 3)	IL	0.9	dB
Max. Insertion Loss (Port 1 to 2, 2 to 3)	IL	1.2	dB
Typ. Isolation (Port 2 to 1, 3 to 2)	Iso	20	dB
Min. Isolation (Port 2 to 1, 3 to 2)	Iso	18	dB
Min. Extinction Ratio	ER	18	dB
Min. Cross Talk	Ct	45	dB
Min. Return Loss	RL	45	dB
Max. Optical Power (CW)	P	300	mW
Max. Tensile Load		5	N
Fiber Type		Nufern PM630-HP fiber	-
Operating Temperature	T	+10~50	°C
Storage Temperature	T	-40~85	°C
Package Dimension			mm

Notice: Above specifications are tested at center wavelength without connector in room temperature @23°C.

For devices with connectors, IL will be 0.3dB higher, ER will be 2dB lower, RL will be 5dB lower.

Drawing:

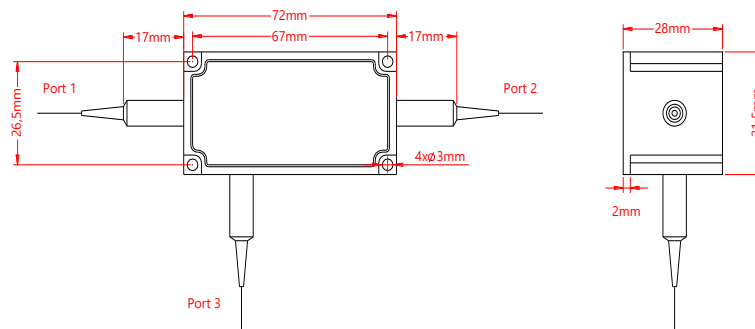

Ordering Information (Part Number):

PM CIR- WWW - P - A - J - LL - CC					
WWW	P	A	J	LL	CC
Wavelength	Port	Working Axis	Fiber Jacket	Fiber Length	Connector
633 - 633nm	3 - 3 Ports	F - Fast Axis Blocked Slow Axis Working B - Both Axes Working	B - 250um Bare Fiber 9 - 900um Loose Tube	05 - 0.5m	NE - None
635 - 635nm				10 - 1.0m	FA - FC/APC
640 - 640nm				15 - 1.5m	FU - FC/UPC
650 - 650nm				20 - 2.0m	SA - SC/APC
680 - 680nm				SS - Specify	SU - SU/APC
SSS - Specify					LA - LC/APC
					LU - LC/UPC
					SS - Specify