

470nm 3-port Polarization Insensitive Optical Circulator

470nm TGG 3-port Polarization Insensitive Optical Circulator is a fiber passive component built with TGG crystal, which can change signal light transmission path, the signal can be delivered from Port 1 to Port 2, the other signal light from Port 2 to Port 3, the high isolation can block the back reflection light. It's widely used in Quantum Communication, Fiber Laser and Coherent Detecting field. If need higher power version please tell us to confirm.

Application:

Quantum Communication
Fiber Laser
Coherent Detecting
Lab&Research

Features:

Low PDL
High Isolation
Low Insertion Loss
High Reliability



Specification:

Parameter	Symbol	Value	Unit
Center Wavelength	λ	470	nm
Bandwidth	BW	± 5	nm
Typ. Insertion Loss (Port 1 to 2, 2 to 3)	IL	1.5	dB
Max. Insertion Loss (Port 1 to 2, 2 to 3)	IL	2.0	dB
Typ. Isolation (Port 2 to 1, 3 to 2)	Iso	20	dB
Min. Isolation (Port 2 to 1, 3 to 2)	Iso	18	dB
Max. Polarization Dependent Loss	PDL	0.2	dB
Min. Cross Talk	Ct	45	dB
Min. Return Loss	RL	45	dB
Max. Optical Power (CW)	P	300 or customized	mW
Max. Tensile Load		5	N
Fiber Type		Nufern 460-HP fiber	-
Operating Temperature	T	+10~50	°C
Storage Temperature	T	-40-85	°C
Package Dimension			mm

Notice: Above specifications are tested at center wavelength without connector in room temperature @23°C.

For devices with connectors, IL will be 0.3dB higher, RL will be 5dB lower.

Drawing:

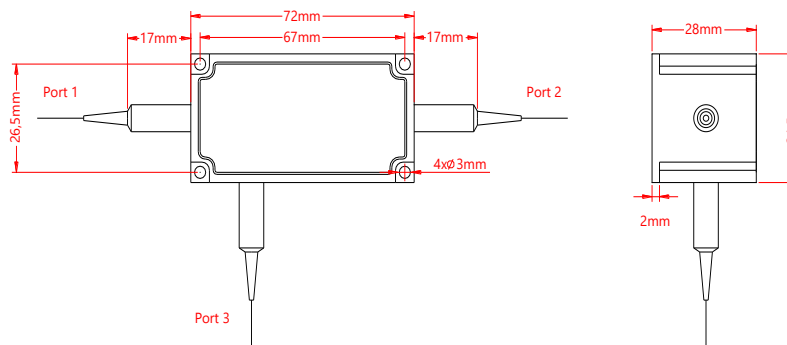

Ordering Information (Part Number):

PICIR- WWW - P - J - LL - CC				
WWW	P	J	LL	CC
Wavelength	Port	Fiber Jacket	Fiber Length	Connector
470 - 470nm	3 - 3 Ports	B - 250um Bare Fiber	05 - 0.5m	NE - None
480 - 480nm		9 - 900um Loose Tube	10 - 1.0m	FA - FC/APC
488 - 488nm			15 - 1.5m	FU - FC/UPC
SSS - Specify			20 - 2.0m	SA - SC/APC
			SS - Specify	SU - SU/APC
				LA - LC/APC
				LU - LC/UPC
				SS - Specify