

CWDM SM Pigtailed DFB Laser Diode

CWDM Wavelength SM Pigtailed DFB (Distributed Feedback) Laser Diode is a semiconductor optoelectronic product which can output stable CWDM laser light from 1270-1610nm by the pigtailed singlemode fiber, it's widely used in CWDM System, Fiber Optic Sensor Application, the DFB Laser Diode also with PD built in to monitor the signal power, the pigtail also can be customized to MM, PM type upon request.

Application:

CWDM System
Fiber Optic Sensor
Laser Imaging
Testing System

Features:

Low Threshold Current
High Output Power
PD and Isolator Built In
High Reliability



Absolute Maximum Ratings:

Parameter	Symbol	Value	Unit
LD Forward Current	If	150	mA
LD Reverse Voltage	Vr	2	V
PD Forward Current	If(PD)	2	mA
PD Reverse Voltage	Vr(PD)	15	V
Operating Temperature	T	-40~+85	°C
Storage Temperature	T	-40~+85	°C
Solder Temperature	T	260	°C
Lead Solder Time		10	S

Notice: Above specifications should not be exceeded, or the LD will be seriously damaged.

Optical and Electrical Specification:

Parameter	Symbol	Min.	Tpy.	Max.	Unit	Test Condition
Center Wavelength	λ_c	λ_c-10	λ_c	λ_c+10	nm	
Optical Power	Po	1	2	4	mW	CW
Spectral Width @-20dB	$\Delta\lambda$		1	2	nm	CW
Optical Isolation	For Single Stage	ISO	30	35	dB	
	For Dual Stage	ISO	50	55	dB	
Threshold Current	Ith	4	10	15	mA	CW
LD Operating Current	Iop		30	35	mA	CW, Po=2mW
LD Forward Voltage	Vf		1.2	1.5	V	CW
Response Time (Raise/Fall)	Tr/Tf			0.4	ns	
Monitor Dark Current	Id			1	nA	Vr(PD)=5V
PD Monitor Current	Im	0.1		1	mA	CW
Modulation Bandwidth	BW	1.25	2.5	4.25	GHz	
Side Mode Suppression Ratio	SMSR	35	40		dB	
Fiber Type	SMF-28e Fiber					

Notice: Above specifications are tested in room temperature at 23°C.

Specifications may change without notice.

Drawing:

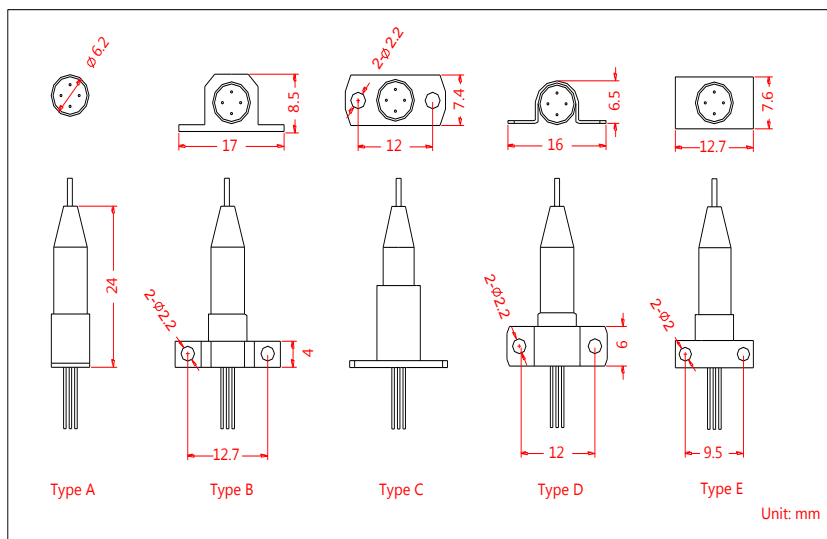

Pin Information:

	Type A		Type B		Type C	
	Pin 1	PD (+)	Pin 1	PD (-)	Pin 1	PD (-)
	Pin 2	LD (+), PD (-)	Pin 2	PD (+)	Pin 2	LD (-)
	Pin 3	Case	Pin 3	LD (+), Case	Pin 3	LD (+), Case
	Pin 4	LD (-)	Pin 4	LD (-)	Pin 4	PD (+)

Ordering Information (Part Number):

SMDPLD-*WWW*-*OO*-*I*-*S*-*P*-*FF*-*J*-*LL*-*CC*

<i>WWW</i>	<i>OO</i>	<i>I</i>	<i>S</i>	<i>P</i>	<i>FF</i>	<i>J</i>	<i>LL</i>	<i>CC</i>
Wavelength	Optical Power	Isolator	Saddle Type	Pin Assingment	Fiber Type	Fiber Jacket	Fiber Length	Connector
1270 - 1270nm	01 - 1mW	N - None	A - Type A	A - Type A	S2 - SMF-28e	B - 250um	05 - 0.5m	NE - None
1290 - 1290nm	02 - 2mW	S - Single	B - Type B	B - Type B		Bare Fiber	10 - 1.0m	FA - FC/APC
.	03 - 3mW	D - Dual	C - Type C	C - Type C		L - 900um	15 - 1.5m	FU - FC/UPC
.	SS - Specify		D - Type D			Loose Tube	20 - 2.0m	LA - LC/APC
.			E - Type E				SS - Specify	LU - LC/UPC
1590 - 1590nm								SA - SC/APC
1610 - 1610nm								SU - SC/UPC
								SS - Specify

Notification:

1. The Semiconductor Optoelectronic products are particularly sensitive of ESD (electro-static discharge), it's recommended to use grounded anti-static wrist straps and grounded anti-static mats before handling the products.
2. Never plug or unplug the products under a living circuit, setting the current supply to zero before switching on or switching off the laser diode.
3. Always take anti-static measures to storage the products when not in use.

