

400-1700nm SM Pigtailed InGaAs Photodiode

400-1700nm SM Pigtailed InGaAs Photodiode is a semiconductor optoelectronic product designed for detecting light signal by transferring the light signal to electric signal, SM Pigtailed InGaAs Photodiode is built with InGaAs chip material and terminated with SM pigtail to detect the light with high responsibility and low dark current, it's widely used in fiber optic sensor and optic electric communication field, the pigtailed fiber can be customized upon request.

Application:

Fiber Communication
Fiber Optic Sensor
Computed Tomography
Testing System

Features:

High Response
Low Dark Current
Low Capacitance
High Reliability



Absolute Maximum Ratings:

Parameter	Symbol	Value	Unit
Reverse Voltage	Vr	15	V
Forward Current	If	5	mA
Operating Temperature	T	-40~+85	°C
Storage Temperature	T	-40~+85	°C
Solder Temperature	T	260	°C
Lead Solder Time		10	S

Notice: Above specifications should not be exceeded, or the Photodiode will be seriously damaged.

Optical and Electrical Specification:

Parameter	Symbol	Min.	Tpy.	Max.	Unit	Condition
Wavelength Range	λ	400		1700	nm	
Saturated Optical Power	P		4		mW	Vr=5V
Dark Current	Id		2		pA	Vr=0V
			10		pA	Vr=5V
Responsivity	R	$\lambda=405\text{nm}$	0.08		A/W	Vr=0V
		$\lambda=650\text{nm}$	0.25		A/W	
		$\lambda=850\text{nm}$	0.45		A/W	
		$\lambda=905\text{nm}$	0.52		A/W	
		$\lambda=1550\text{nm}$	0.90		A/W	
Operating Voltage	Vr	0		5	V	
Breakdown Reverse voltage	Vb			30	V	Ir=10uA
Frequency Bandwidth	Bw		1.5		GHz	
Junction capacitance	Cj		30		Pf	Vr=0V
			2		Pf	Vr=5V
Active Diameter	Ad		0.1		mm	
Response Time (Raise/Fall)	Tr/Tf		0.25		ns	
Return Loss	RL	45	50		dB	
Fiber Type		SM Fiber				

Notice: Above specifications are tested in room temperature at 25°C.

Specifications may change without notice.

Wavelength VS Responsivity Curve:

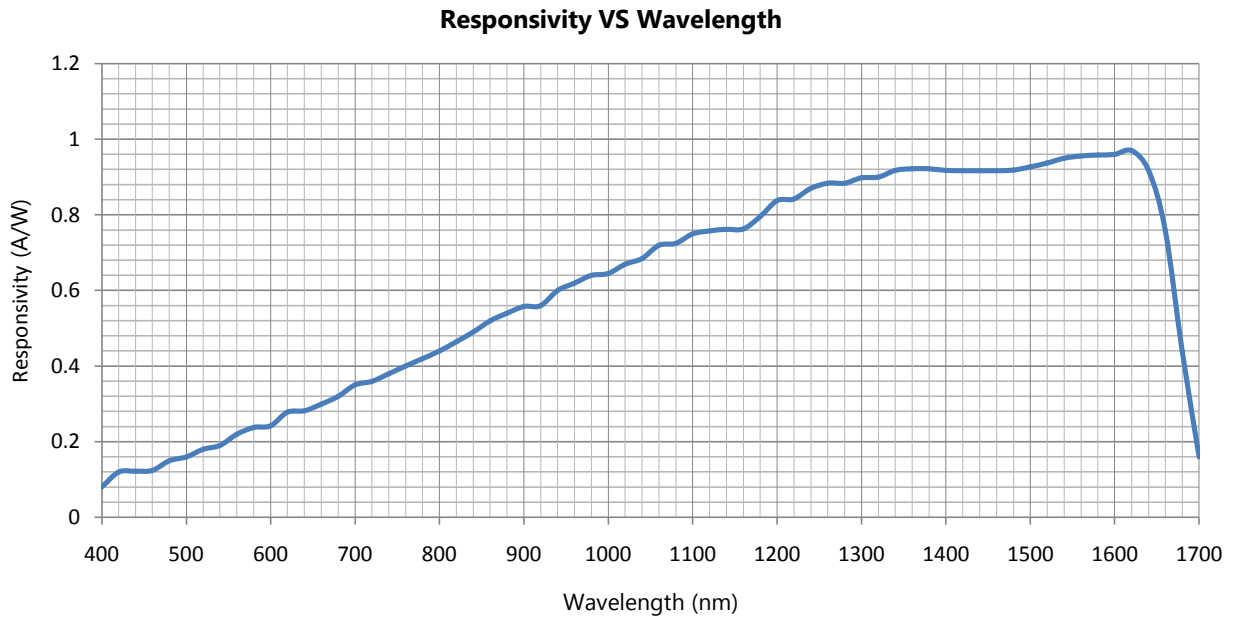

Drawing:

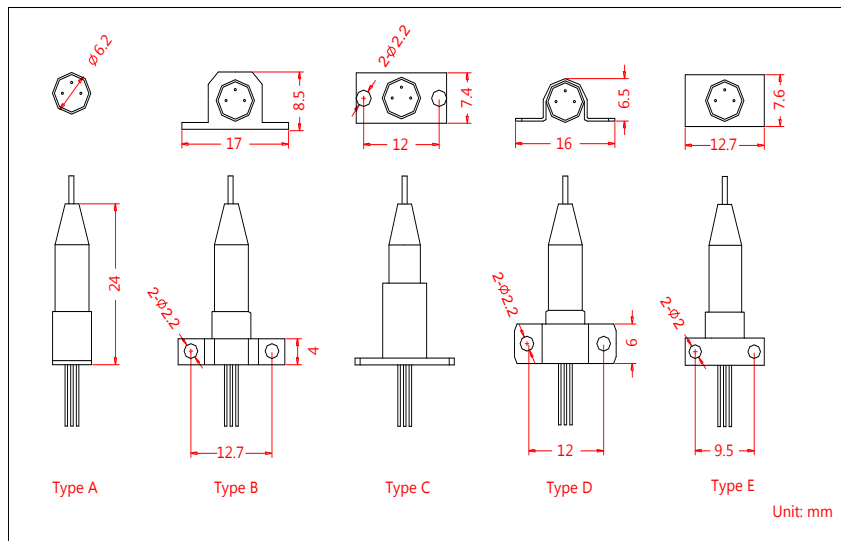

Pin Information:

	Type A		Type B		Type B	
	Pin 1	PD +	Pin 1	PD +	Pin 1	PD +
	Pin 2	PD -	Pin 2	PD -	Pin 2	Case
	Pin 3	Case	Pin 3	Case	Pin 3	PD -

Ordering Information (Part Number):

SMIPD-<i>WWW-AA-S-P-J-LL-CC</i>						
WWW	AA	S	P	J	LL	CC
Test Wavelength	Active Diameter	Saddle Type	Pin Assingment	Fiber Jacket	Fiber Length	Connector
405 - 405nm	Z1 - Φ 0.1mm	A - Type A	A - Type A	B - 250um Bare Fiber	05 - 0.5m	NE - None
650 - 650nm	SS - Specify	B - Type B	B - Type B	L - 900um Loose Tube	10 - 1.0m	FA - FC/APC
850 - 850nm		C - Type C	C - Type C		15 - 1.5m	FU - FC/UPC
905 - 905nm		D - Type D			20 - 2.0m	LA - LC/APC
1550 - 1550nm		E - Type E			SS - Specify	LU - LC/UPC
SSS - Specify						SA - SC/APC
						SU - SC/UPC
						ST - ST/UPC

Notification:

1. The Semiconductor Optoelectronic products are particularly sensitive of ESD (electro-static discharge), it's recommended to use grounded anti-static wrist straps and grounded anti-static mats before handling the products.
2. Always take anti-static measures to storage the products when not in use.

